

DEKLARACJA WŁAŚCIWOŚCI UŻYTKOWYCH
ESDS-6-Z-Z16-63

EUROFAST®

Nr: 14880739031-16-2023-A

PL (Polish)

1. Niepowtarzalny kod identyfikacyjny typu wyrobu:

ESDS-6-Z-Z16-63...

2. Zamierzone zastosowanie lub zastosowania:

WKRĘTY DO MOCOWANIA ELEMENTÓW METALOWYCH I BLACH

3. Producent:

Van Roij Fasteners Europe B.V. | Indumastraat 18 | 5753 RJ Deurne | Netherlands

4. Upoważniony przedstawiciel:

Nie dotyczy

5. System(-y) oceny i weryfikacji stałości właściwości użytkowych:

System 2 +

6. Europejski dokument oceny:

EAD 330046-01-0602 (z: 01.2016)

Europejska ocena techniczna:

ETA-16/0739 (wydana: 30.03.2021)

Jednostka ds. oceny technicznej:

ITB (1488)

Jednostka lub jednostki notyfikowane:

ITB (AC020) Certyfikat: 1488-CPR-0624/Z

7. Deklarowane właściwości użytkowe:

Zasadnicze charakterystyki	Właściwości użytkowe	Zharmonizowana Specyfikacja Techniczna
Wytrzymałość połączenia na ścinanie	Zobacz na następnej stronie/stronach: Załącznik 68, 71	ETA-16/0739
Odporność połączenia na rozciąganie	Zobacz na następnej stronie/stronach: Załącznik 68, 71	ETA-16/0739
Nośność obliczeniowa w przypadku połączonych sił rozciągających i ścinających (interakcja)	Zobacz na następnej stronie/stronach: Załącznik 68, 71, 131	ETA-16/0739
Zdolność do odkształcenia w przypadku sił spowodowanych temperaturą	NPD	-
Trwałość	NPD	-
Reakcja na ogień	A1	ETA-16/0739

Właściwości użytkowe określonego powyżej wyrobu są zgodne z zestawem deklarowanych właściwości użytkowych. Niniejsza deklaracja właściwości użytkowych wydana zostaje zgodnie z rozporządzeniem (UE) nr 305/2011 na wyłączną odpowiedzialność producenta określonego powyżej.

Kopia Deklaracji Właściwości Użytkowych jest dostępna na stronie www.eurofastgroup.com

W imieniu producenta podpisał(-a):

Kjell Verdonschot
Chief Executive Officer C.E.O



w Deurne dnia 28.09.2023

Zgodnie z załącznikiem III do rozporządzenia (UE) nr 574/2014 z dnia 21 lutego 2014.

Materials

Fastener: carbon steel – SAE1022, quenched, tempered and coated: galvanized (12 µm)
 Washer: Z16 – carbon steel galvanized washer with EPDM ring
 Component I: S280GD, S320GD or S350GD – EN 10326
 Component II: S235 – EN 10025-1
 S280GD, S320GD or S350GD – EN 10346

Drilling capacity: $\Sigma t_i \leq 6,00$ mm

Timber substructures

No performance assessed

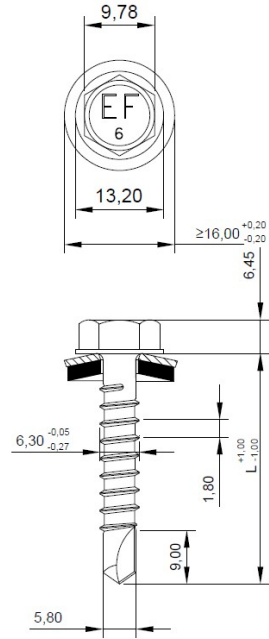

$t_{N,II}$ [mm]	3,00	4,00	5,00	Wood class \geq C24
$M_{t,nom}$	7 Nm			
$V_{R,k}$ [kN] for $t_{N,I}$ [mm]	0,50	1,72	1,72	1,72
	0,55	1,72	1,72	1,72
	0,60	1,72	1,72	1,72
	0,63	1,90	1,90	1,90
	0,70	1,90	1,90	1,90
	0,75	2,69	2,69	2,69
	0,80	2,69	2,69	2,69
	0,88	2,69	2,69	2,69
	1,00	3,10	3,10	3,10
	1,13	3,10	3,10	—
	1,15	3,10	3,10	—
	1,25	3,10	3,10	—
	1,50	3,10	3,10	—
	1,75	3,10	3,10	—
2,00	3,10	3,10	—	
$N_{R,k}$ [kN] for $t_{N,I}$ [mm]	0,50	2,65	2,65	2,65
	0,55	2,65	2,65	2,65
	0,60	2,65	2,65	2,65
	0,63	3,63	3,63	3,63
	0,70	3,63	3,63	3,63
	0,75	3,98	3,98	4,27
	0,80	3,98	3,98	4,27
	0,88	3,98	3,98	4,27
	1,00	3,98	3,98	4,75
	1,13	3,98	3,98	—
	1,15	3,98	3,98	—
	1,25	3,98	3,98	—
	1,50	3,98	3,98	—
	1,75	3,98	3,98	—
2,00	3,98	3,98	—	

If both components I and II are made of S320GD the values $V_{R,k}$ may be increased by 8,3%
 If both components I and II are made of S350GD the values $V_{R,k}$ may be increased by 16,6%

Fastening screws for metal members and sheeting

Self-drilling screws ESDS-6-Z 6.3xL
 with hexagon head and washer Z16

Materials

Fastener: carbon steel – SAE1022, quenched, tempered and coated: galvanized (12 µm)
 Washer: Z16 – carbon steel galvanized washer with EPDM ring
 Saddle washer: ESW made of aluminum
 Component I: S280GD, S320GD or S350GD – EN 10326
 Component II: S235 – EN 10025-1
 S280GD, S320GD or S350GD – EN 10346

Drilling capacity: $\Sigma ti \leq 6,00$ mm

Timber substructures

No performance assessed

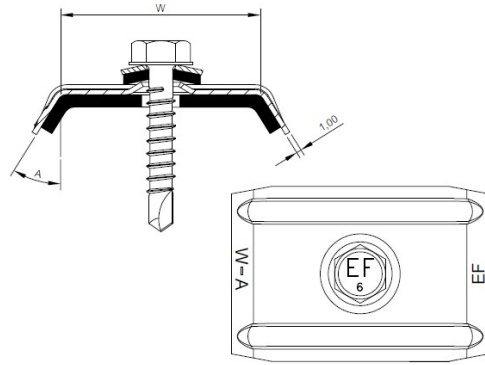

$t_{N,II}$ [mm]	3,00	4,00	5,00	Wood class \geq C24
$M_{t,nom}$	7 Nm			
$V_{R,k}$ [kN] for $t_{N,I}$ [mm]	0,50	1,72	1,72	1,72
	0,55	1,72	1,72	1,72
	0,60	1,72	1,72	1,72
	0,63	1,90	1,90	1,90
	0,70	1,90	1,90	1,90
	0,75	2,69	2,69	2,69
	0,80	2,69	2,69	2,69
	0,88	2,69	2,69	2,69
	1,00	3,10	3,10	3,10
	1,13	3,10	3,10	—
	1,15	3,10	3,10	—
	1,25	3,10	3,10	—
	1,50	3,10	3,10	—
	1,75	3,10	3,10	—
2,00	3,10	3,10	—	
$N_{R,k}$ [kN] for $t_{N,I}$ [mm]	0,50	3,98	3,98	8,50
	0,55	3,98	3,98	8,50
	0,60	3,98	3,98	8,50
	0,63	3,98	3,98	8,50
	0,70	3,98	3,98	8,50
	0,75	3,98	3,98	8,50
	0,80	3,98	3,98	8,50
	0,88	3,98	3,98	8,50
	1,00	3,98	3,98	8,50
	1,13	3,98	3,98	—
	1,15	3,98	3,98	—
	1,25	3,98	3,98	—
	1,50	3,98	3,98	—
	1,75	3,98	3,98	—
2,00	3,98	3,98	—	

If both components I and II are made of S320GD the values $V_{R,k}$ may be increased by 8,3%
 If both components I and II are made of S350GD the values $V_{R,k}$ may be increased by 16,6%

Fastening screws for metal members and sheeting

Self-drilling screws ESDS-6-Z 6.3xL
 with hexagon head and washer Z16 and saddle washer ESW

Annex 71

Determination of design values

1. Determination of Design Shear Resistance

The determination of the design values of the shear resistance depends on the type of supporting substructure.

For Metal Substructures the following applies:

The design values $V_{R,d}$ of the shear resistance are the characteristic values of the shear resistance divided by the recommended partial safety factor $\gamma_M = 1,33$. The recommended partial safety factor γ_M should be used in cases where no value is given in national regulations of the Member State where the fastening screws are used.

For Timber Substructures the following applies:

The design values $V_{R,d}$ of the shear resistance are the characteristic values of the shear resistance multiplied by k_{mod} according to EN 1995-1-1, Table 3.1, and divided by the recommended partial safety factor $\gamma_M = 1,33$. If failure of the metal component with the thickness t and not failure of the timber substructure is the relevant failure mode then $k_{mod} = 1,0$.

The recommended partial safety factor γ_M should be used in cases where no value is given in national regulations of the Member State where the fastening screws are used.

2. Determination of Design Pull-through, Pull-out and Tension Resistance

The design values of the pull-through resistance are the characteristic values of the pull-through resistance divided by the recommended partial safety factor $\gamma_M = 1,33$. The recommended partial safety factor γ_M should be used in cases where no value is given in national regulations of the Member State where the fastening screws are used.

The determination of the design values of the pull-out resistance depends on the type of substructure.

For Metal Substructures the following applies:

The design values of the pull-out resistance are the characteristic values of the pull-out resistance divided by the recommended partial safety factor $\gamma_M = 1,33$. The recommended partial safety factor γ_M should be used in cases where no value is given in national regulations of the Member State where the fastening screws are used.

For Timber Substructures the following applies:

The design values of the pull-out resistance are the characteristic values of the pull-out resistance multiplied by k_{mod} according to EN 1995-1-1, Table 3.1, and divided by the recommended partial safety factor $\gamma_M = 1,33$. The recommended partial safety factor γ_M should be used in cases where no value is given in national regulations of the Member State where the fastening screws are used.

The design tension resistance $N_{R,d}$ is the minimum value of the design values of either pull-through resistance or relevant pull-out resistance for the corresponding connection.

3. Design Resistance in case of combined Tension and Shear Forces (interaction)

In case of combined tension and shear forces the linear interaction formula according to EN 1993-1-3, section 8.3 (8) or EN 1999-1-4, section 8.1 (7) should be taken into account.

Fastening screws for metal members and sheeting

Annex 131

Determination of design values